

Features

- ⊕ Linear, exponential, logarithmic, double logarithmic or custom-made
- ⊕ Very accurate resistance tapers
- ⊕ Resistance values and tolerances are customer specified

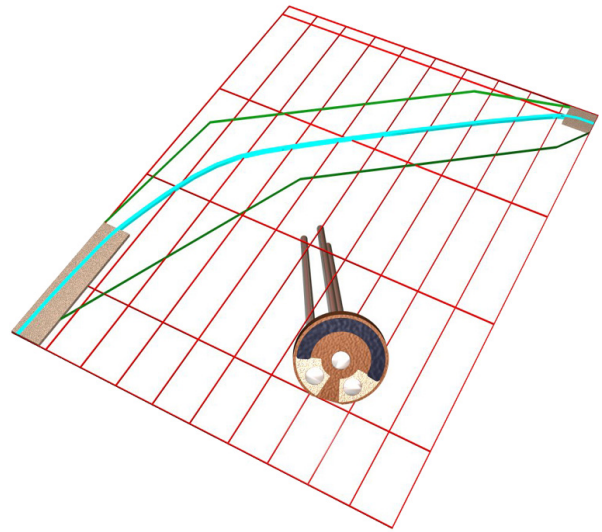

Contents



	Page
History Revision	2
Taper Overview	3
Available Variations.....	3
Comparative Taper Charts	4
Taper Replacement Guide	8
Taper Terminology	9
Description	9
Taper Tolerances.....	10
Resistance Value and Range.....	10
General Guidelines	10
Taper Variations.....	11
Taper No. 01	13
Taper Nos. 02-03 (shown as 10 kΩ)	14
Taper Nos. 02-03 (shown as 50 kΩ)	15
Taper Nos. 22-23	16
Taper Nos. 24-25	17
Taper Nos. 26-27	18
Taper Nos. 28-29	19
Taper No. 30	20
Taper Nos. 31-32	21
Taper Nos. 33-34	22
Taper Nos. 35-36	23
Taper Nos. 41-42	24
Taper Nos. 43-44	25
Taper Nos. 45-46	26
Taper Nos. 81-82	27
Taper Nos. 83-84	28
Taper Nos. 85-86	29
Taper Nos. 87-88	30

Sonion reserves the right to make changes at any time to improve reliability, function or design, in order to provide the best product possible.

History Revision

Revision Number/Date	Change from last revision
05 / May. 02	History Revision added. Tapers nos. 5 and 10 for Pin Trimmers have been removed
06 / Jan. 03	Taper overview added
07 / May 08	Taper overview updated
MT1027.A (07/08)	No technical updates
008/JUL-22-2009	No technical updates

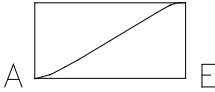
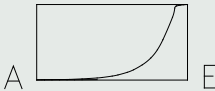
Taper Overview

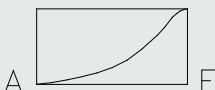
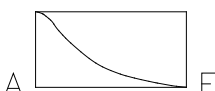
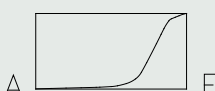
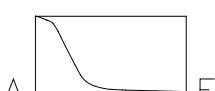
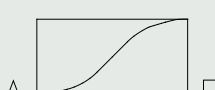
Type		Taper No.	Available Variations
Linear		01	All
Exponential CW style		02	Standard Minus E Open minus E
Exponential CCW style		03	Standard Minus A Open minus A
Logarithmic CW style		22, 24, 26, 28, 32, 34 & 36	Standard Minus E Open minus E
Logarithmic CCW style		23, 25, 27, 29, 31, 33, & 35	Standard Minus A Open minus A
Double logarithmic CW style		42, 44, 46, 82, 84, 86 & 88	Standard Minus E Open minus E
Double logarithmic CCW style		41, 43, 45, 81, 83, 85 & 87	Standard Minus A Open minus A
S shape		30	All

Available Variations

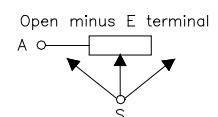
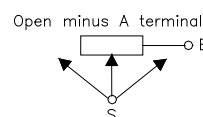
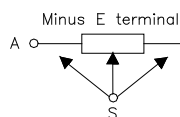
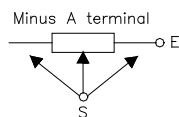
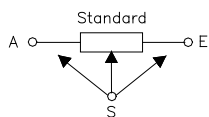

Taper Nos. 30, 32, 34 & 36

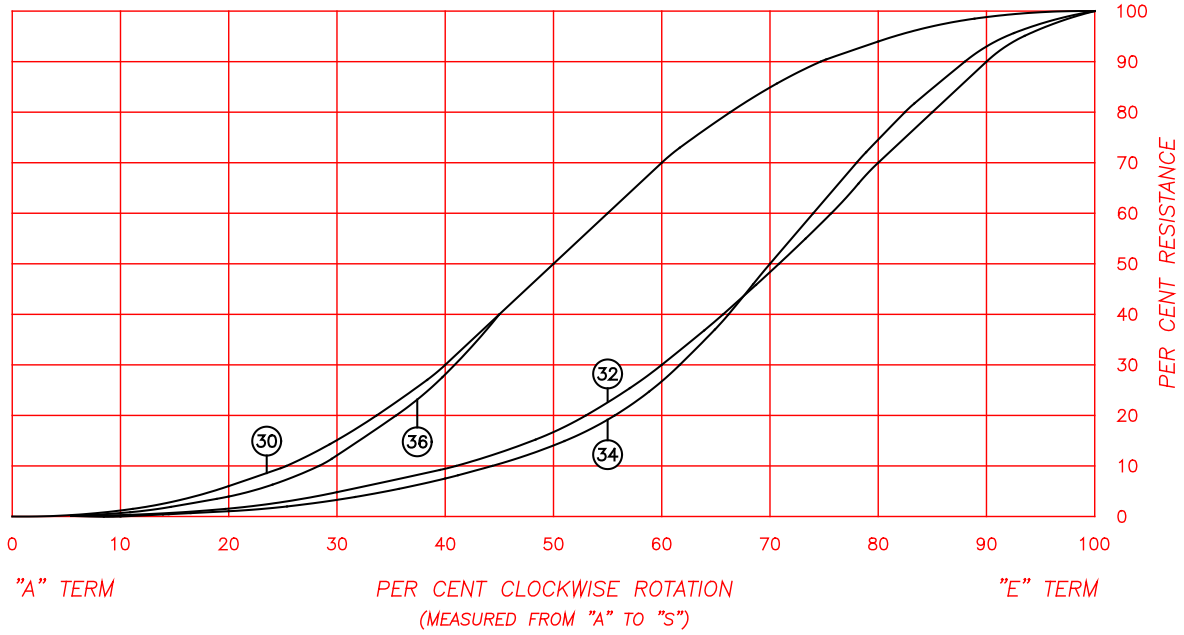

Taper Nos. 30, 31, 33 & 35

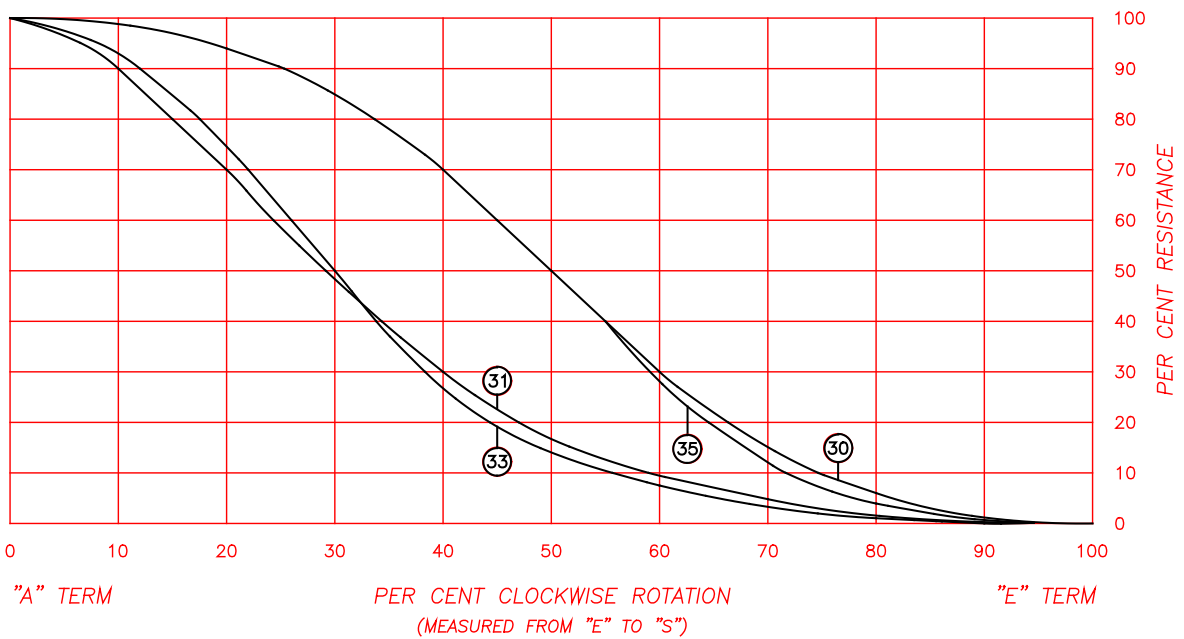

Taper Nos. 42, 44 & 46

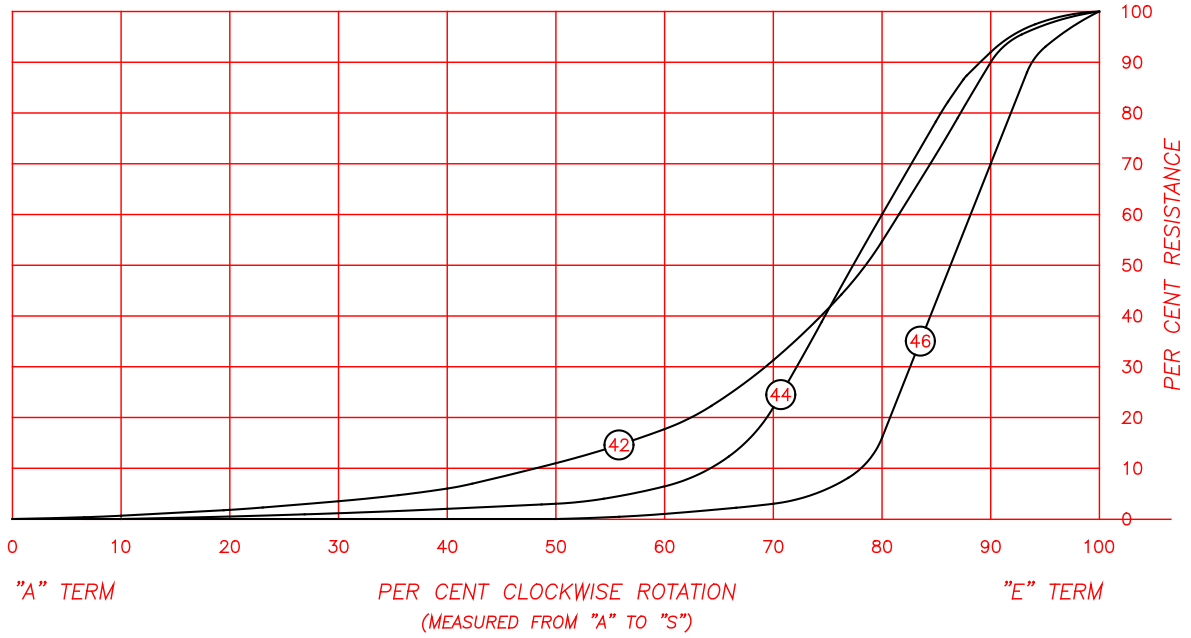

Taper Nos. 41, 43 & 45

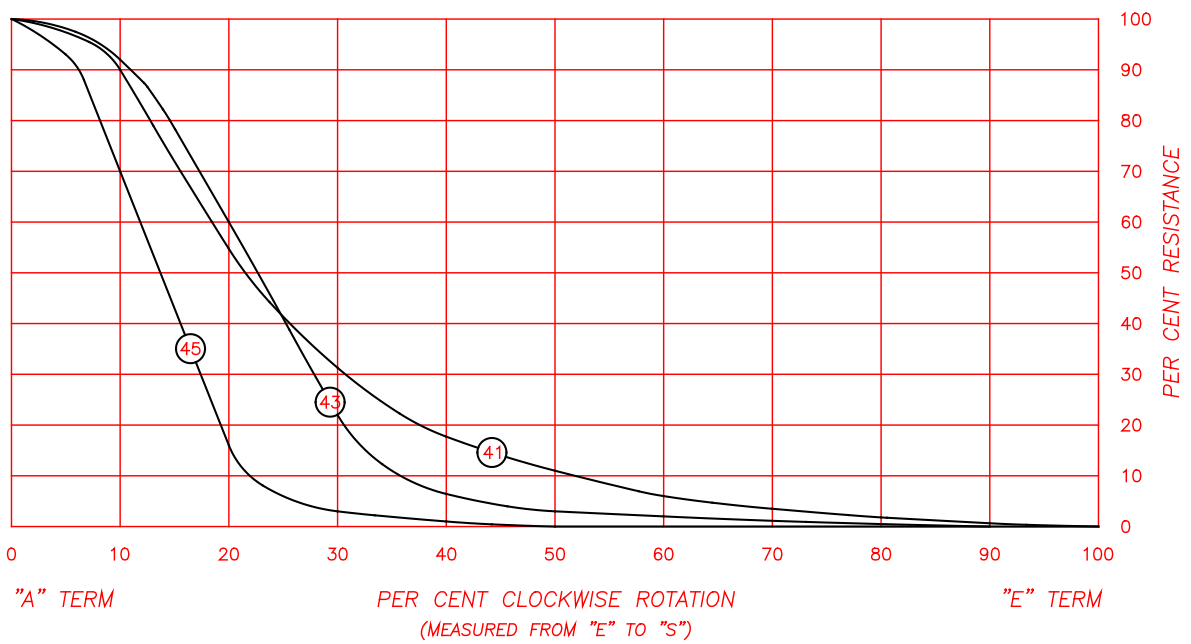

Taper Nos. 82, 84, 86 & 88

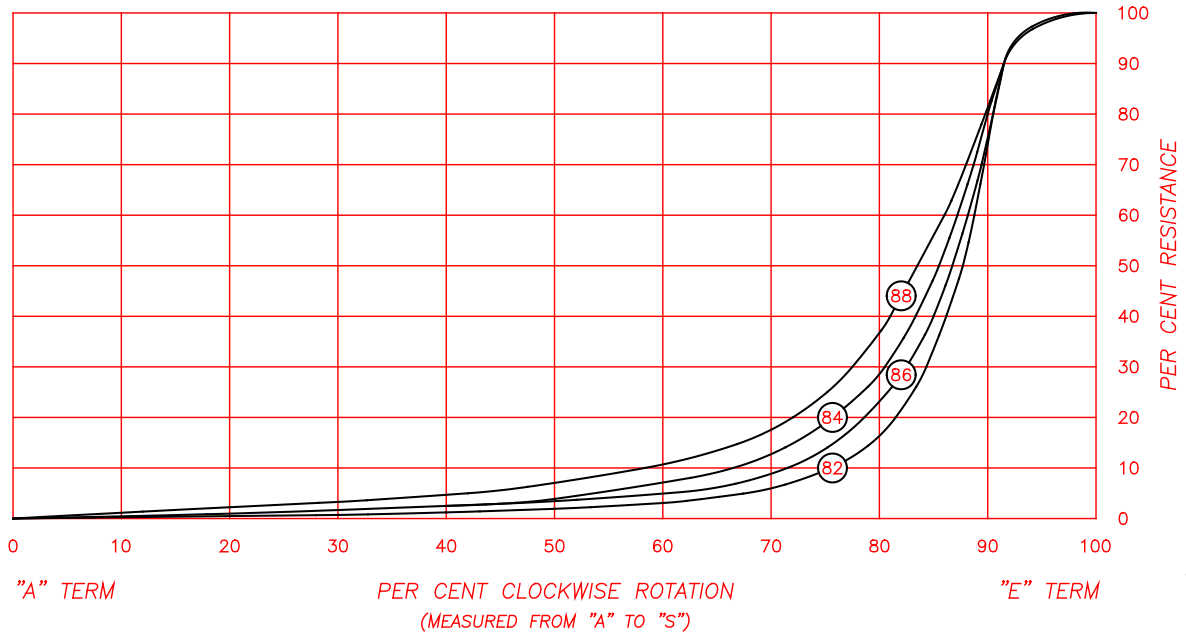

Taper Nos. 81, 83, 85 & 87

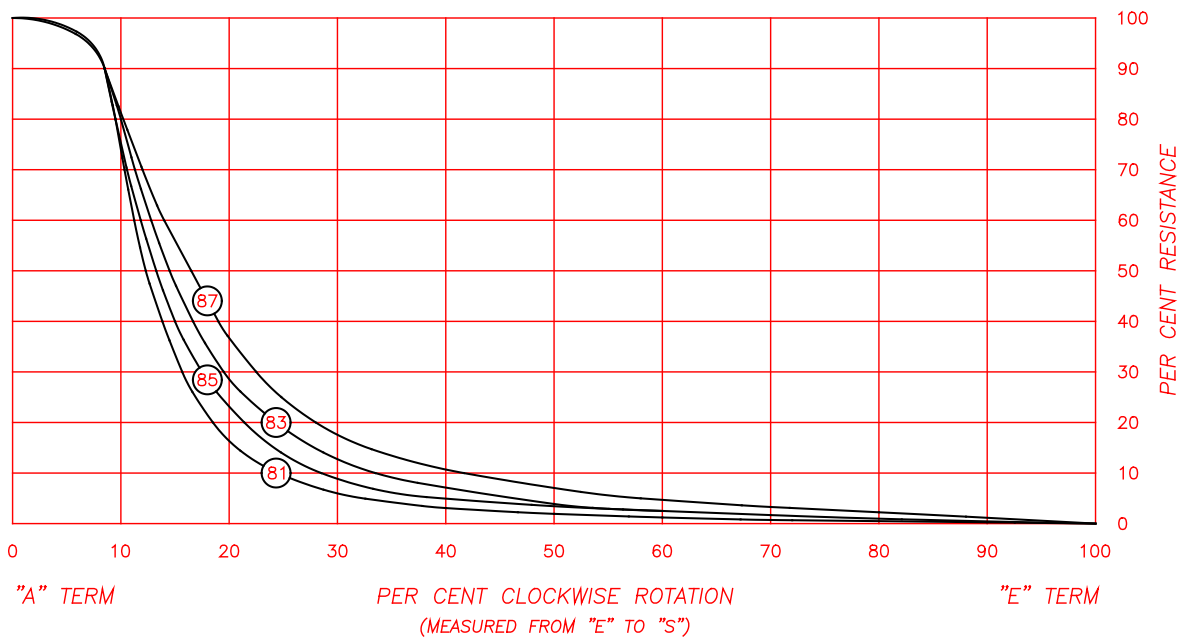

Taper Replacement Guide

Type	Taper	Sonion equivalent taper
Knowles	00, 01	01
	06, 07	22, 23
	02, 03	24, 25
	04, 05	26, 27
	28, 29	28, 29
	05, 04	33, 34
	09, 08	81, 82
	IntriCon Corp.	C01, C06
C22, C23		22, 23
C24, C25		24, 25
C26, C27		26, 27
C28, C29		28, 29
C07, C08		30 / 35, 36
C31, C32		31, 32
C33, C34		33, 34
C81, C82		81, 82
C83, C84		83, 84
C85, C86		85, 86
C87, C88		87, 88

Please Note: Not all matches are exact

Taper Terminology

CW

- Clockwise rotation, the wiper travels from terminal A to terminal E on the taper.

CCW

- Counter clockwise rotation, the wiper travels from terminal E to terminal A on the taper.

A terminal:

- Start of taper, see drawing below

E terminal:

- End of taper, see drawing below

S terminal:

- Terminal connected to wiper

Taper curve:

- A curve describing the resistance value of the taper as a function of the wiper position

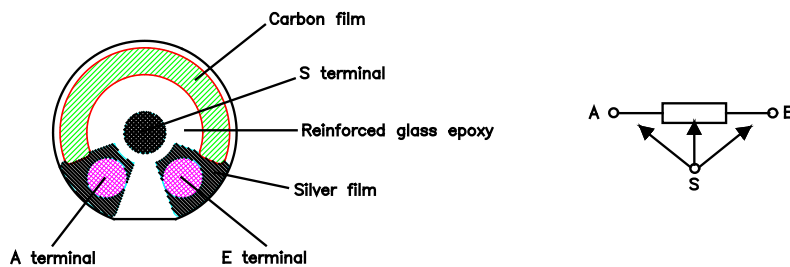

Description

The Sonion tapers are based on our unique patented technology which allows manufacturing of smooth and accurate resistance tapers. Basically, the taper consist of a carbon film printed onto glass reinforced epoxy. To achieve the different taper shapes available, the carbon film is printed by depositing a number of fine drops of a carbon ink liquid solution onto the epoxy plate, each drop having a specific conductivity matching the taper specification for the position at which the drop is placed. When the carbon drops are placed they merge together, giving a smooth transition between the different conductivities and therefore a very smooth curve shape.

At each end of the carbon film a silver film is printed connecting the taper to the terminals A and E. The wiper forms the connection between the taper and the S terminal.

Resistance value range

All taper curves:

Linear	200Ω to 1MΩ
Logarithmic	500Ω to 700kΩ
Double logarithmic	2kΩ to 500kΩ
Exponential	500Ω to 700kΩ

Taper Tolerances

The taper curve tolerance is specified as:

- A tolerance band, specifying the acceptable resistance range for each position of the wiper. Information concerning the nominal curve and the tolerance band for each curve type can be found on the following pages.
- Tolerance on the total resistance value, which is standard $\pm 20\%$ or $+30, -20\%$ for less than $1\text{k}\Omega$.
- Bottom/high end resistance value which is max. 100Ω

Resistance Value and Range

Resistance values

Values between 200Ω and 1000Ω can be specified in 10Ω steps, like 460Ω , 970Ω , etc.

Values between $1\text{k}\Omega$ and $10\text{k}\Omega$ can be specified in 100Ω steps, like 1100Ω , 8800Ω , etc.

Values between $10\text{k}\Omega$ and $100\text{k}\Omega$ can be specified in $1\text{k}\Omega$ steps, like $47\text{k}\Omega$ and $63\text{k}\Omega$, etc.

Values between $100\text{k}\Omega$ and $1\text{M}\Omega$ can be specified in $10\text{k}\Omega$ steps, like $130\text{k}\Omega$, $560\text{k}\Omega$, etc.

General Guidelines

Exponential, logarithmic and double logarithmic curves are available in two versions, one for CW and one for CCW applications.

Taper curves designed for CW applications has even reference numbers like 22, 24, 26, etc.

Taper curves designed for CCW applications has odd reference numbers like 23, 25, 27, etc.

Taper curve 22 and 23 are inverse curves, but with the same basic shape. The behaviour of taper curve 22 with the wiper turned CW from A to E terminal and the resistance measured between the wiper and terminal A is identical to taper curve 23 with the wiper turned CCW from E to A and the resistance measured between the wiper and terminal E.

Resistance between the "A" terminal and the wiper "S"

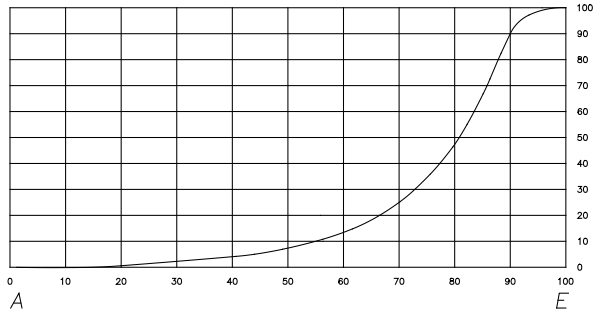

Resistance between the "E" terminal and the wiper "S"

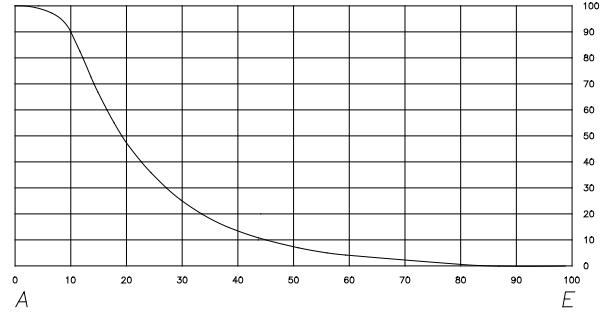

Taper Variations

Two terminal version, delivered without the A or E terminal

This option is used for two terminal trimmers or volume controls. See drawing below.

Two terminal taper without the E terminal

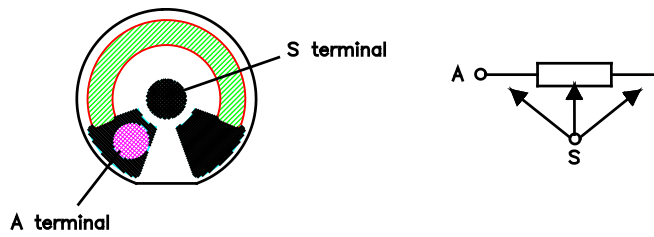

Two terminal taper without the A terminal

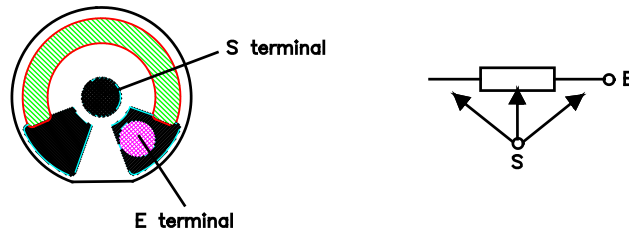

Two terminal open version, without the A or E terminal

This is a special version of the 2 terminal taper. The silver film is omitted together with the terminal, resulting in a disconnection between the wiper and the taper, when the wiper is moved to the end stop. See drawing below.

Two terminal open taper without the E terminal

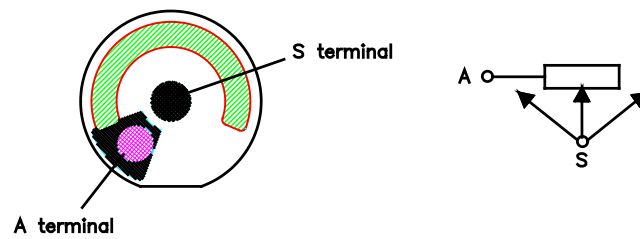

Two terminal open taper without the A terminal

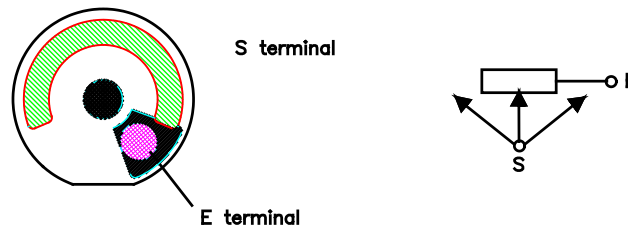

Two terminal versions of logarithmic and exponential curves, general remarks

As a general rule, curves with even references like 22, 24 26, etc. are designed to be used between the terminals A and S. Tapers using these curves should therefore not be defined without the A terminal unless for very special applications. Curves with odd references are designed to be used between terminal E and S. Tapers using these curves should therefore not be defined without the E terminal unless for very special applications.

Taper No. 01

Linear

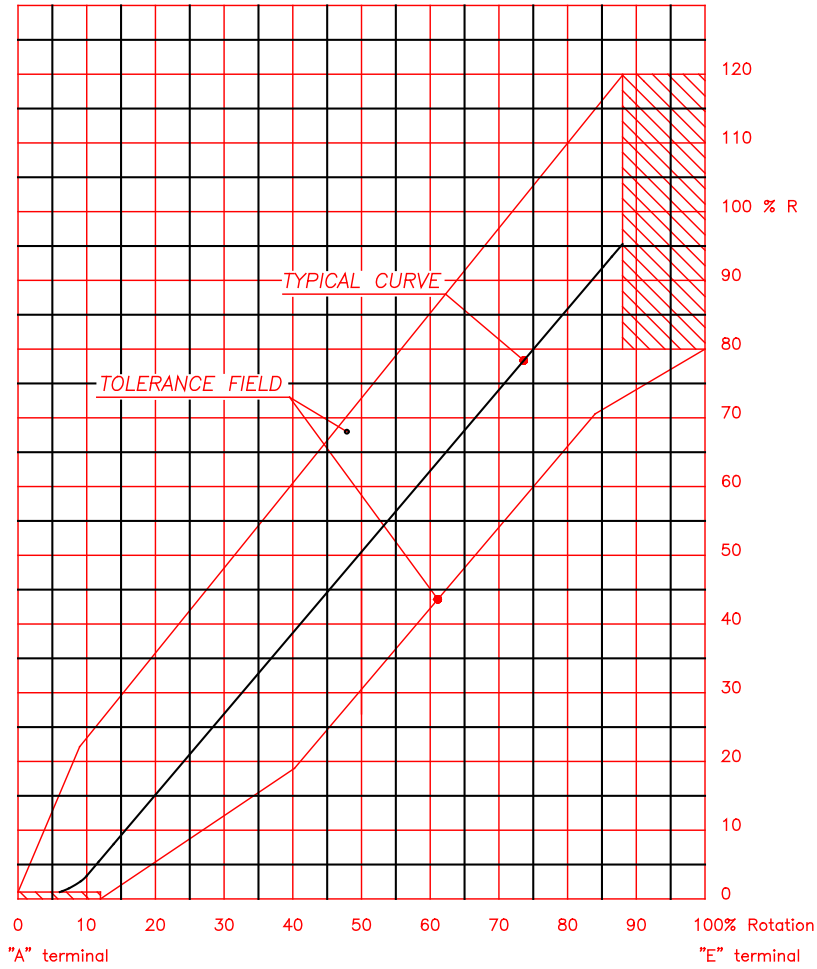

Taper Nos. 02-03 (shown as 10 kΩ)

Positive exponential - clockwise rotation

Negative exponential - counter clockwise rotation

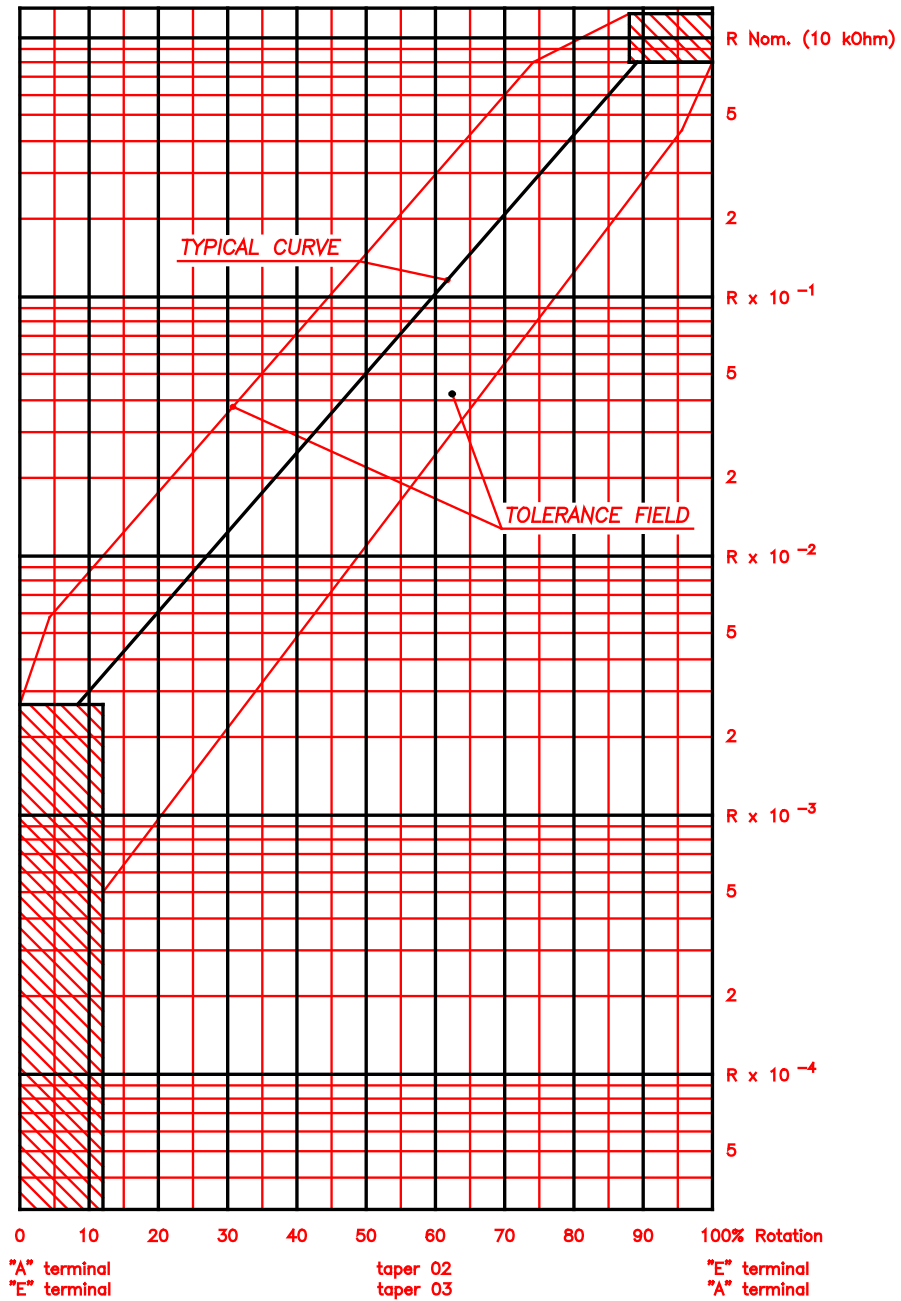

Taper Nos. 02-03 (shown as 50 kΩ)

Positive exponential no. 02 - clockwise rotation

Negative exponential no. 03 - counter clockwise rotation

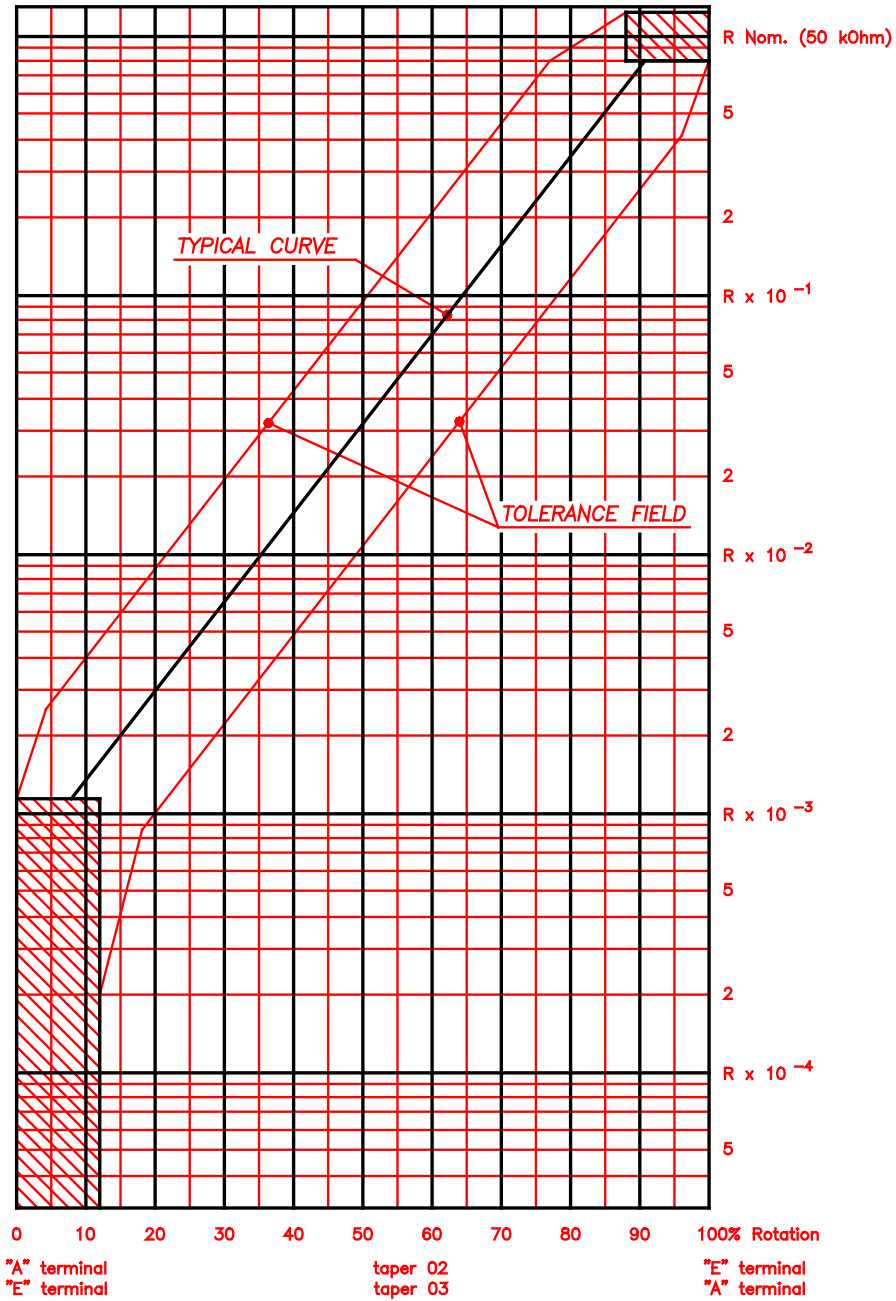

Taper Nos. 22-23

Positive logarithmic no. 22 - clockwise rotation

Negative logarithmic no. 23- counter clockwise rotation

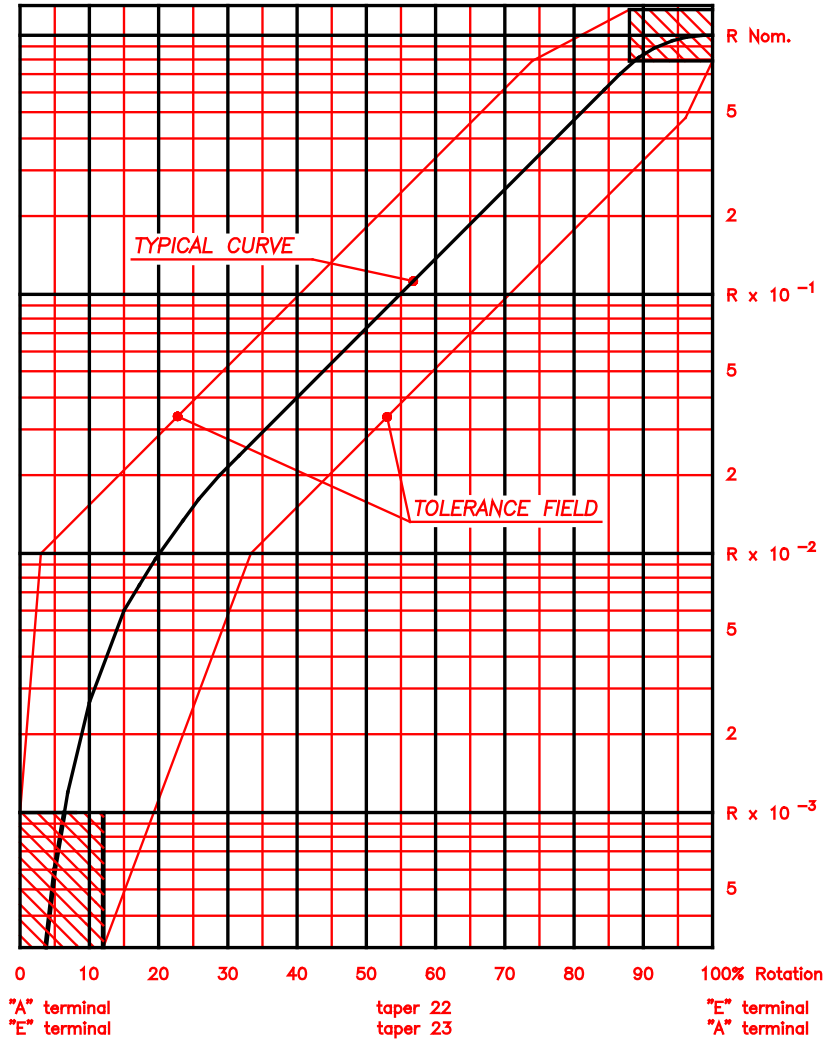

Taper Nos. 24-25

Positive log no. 24 - clockwise rotation

Negative log no. 25 - counter clockwise rotation

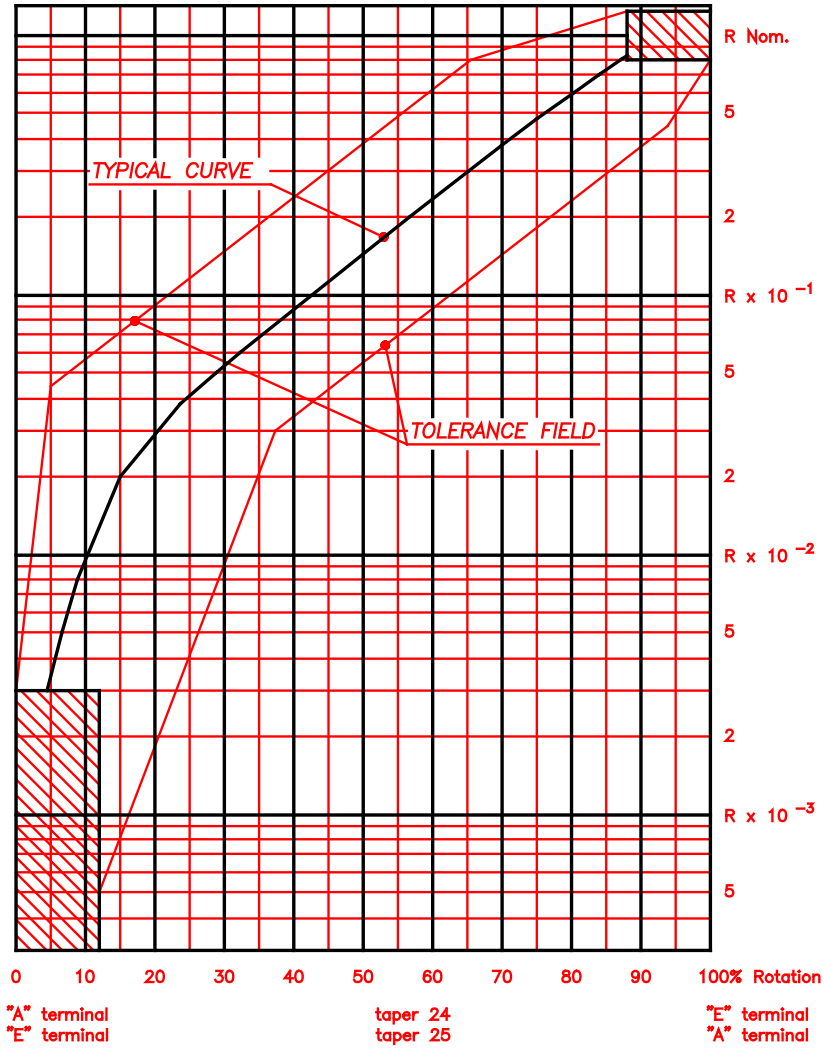

Taper Nos. 26-27

Positive logarithmic no. 26 - clockwise rotation

Negative logarithmic no. 27 - counter clockwise rotation

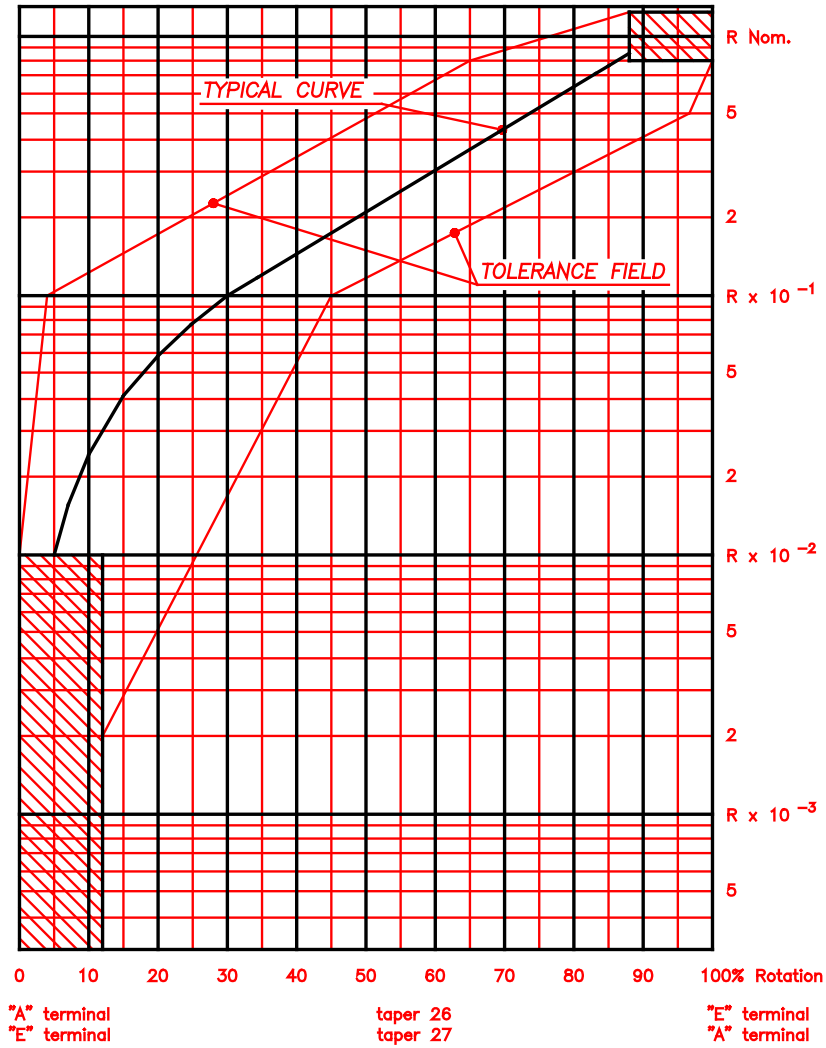

Taper Nos. 28-29

Positive logarithmic no. 28 - clockwise rotation

Negative logarithmic no. 29 - counter clockwise rotation

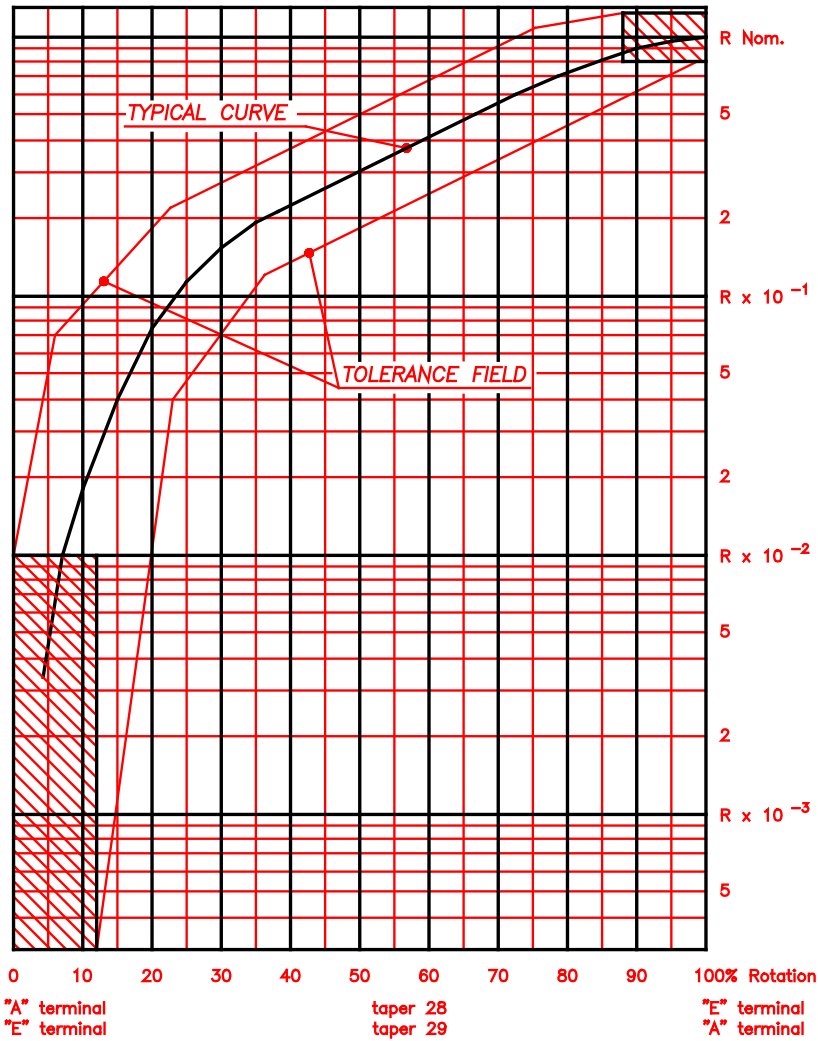

Taper No. 30

S taper curve

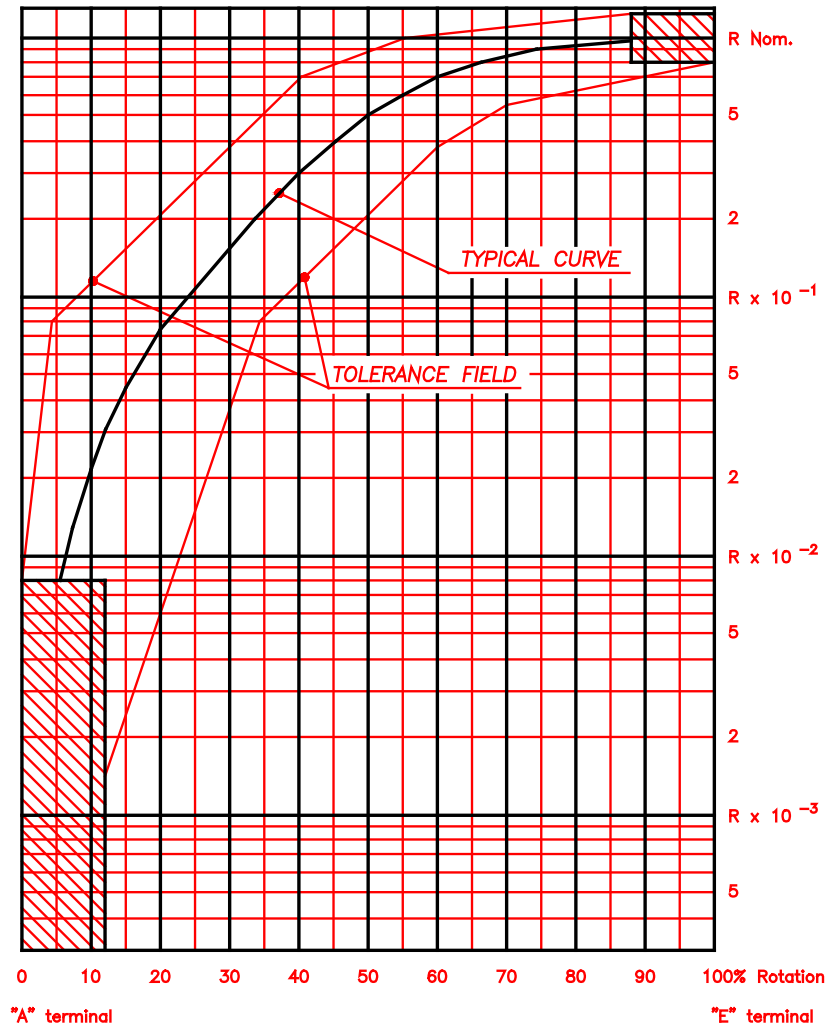

Taper Nos. 31-32

Negative logarithmic no. 31 - counter clockwise rotation

Positive logarithmic no. 32 - clockwise rotation

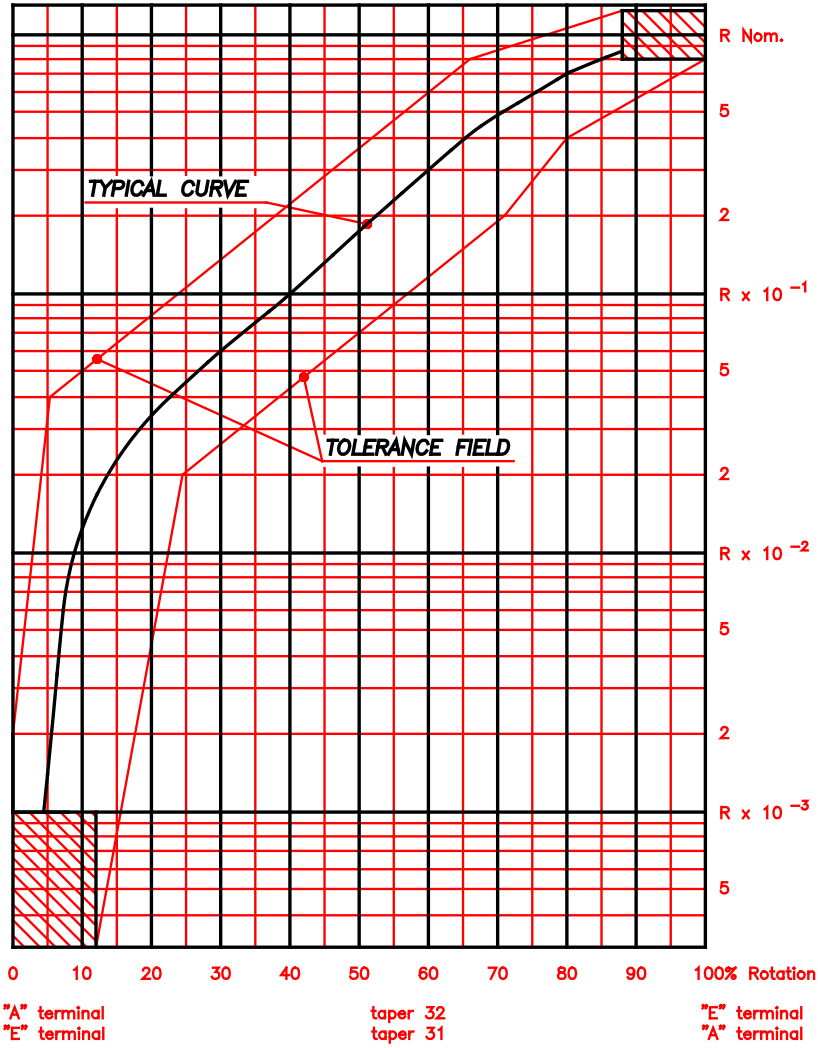

Taper Nos. 33-34

Negative logarithmic no. 33 - counter clockwise rotation

Positive logarithmic no. 34 - clockwise rotation

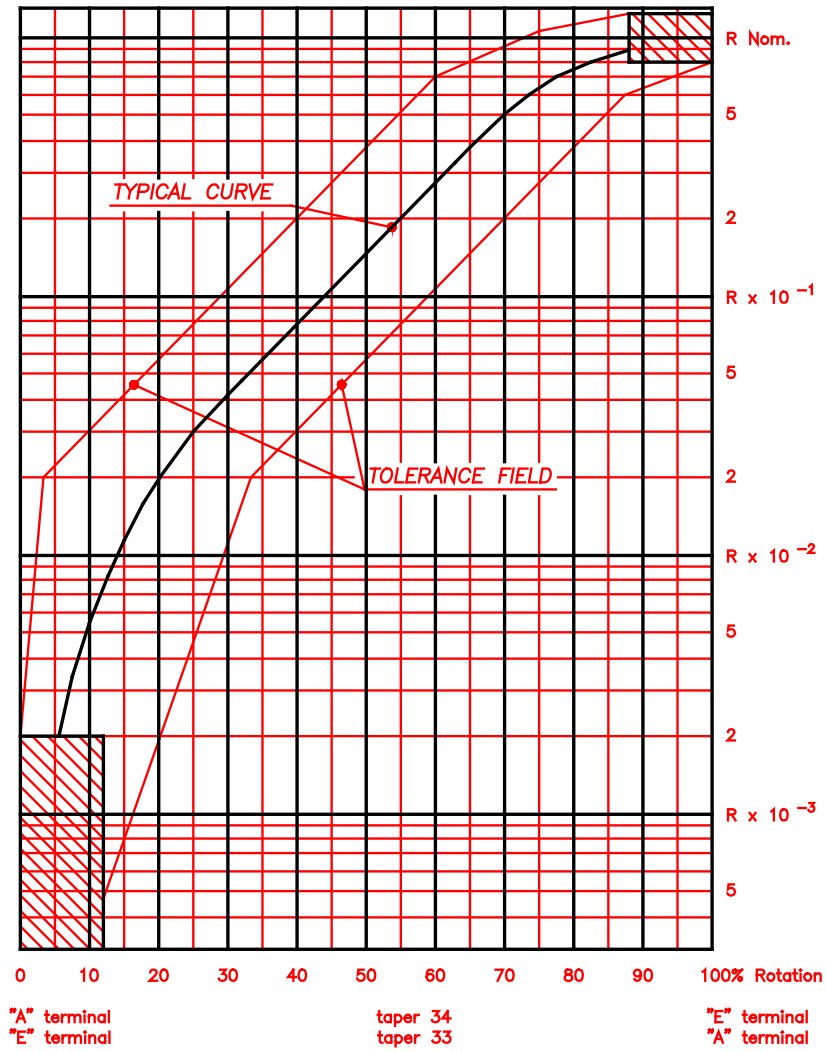

Taper Nos. 35-36

Negative logarithmic no. 35 - counter clockwise rotation

Positive logarithmic no. 36 - clockwise rotation

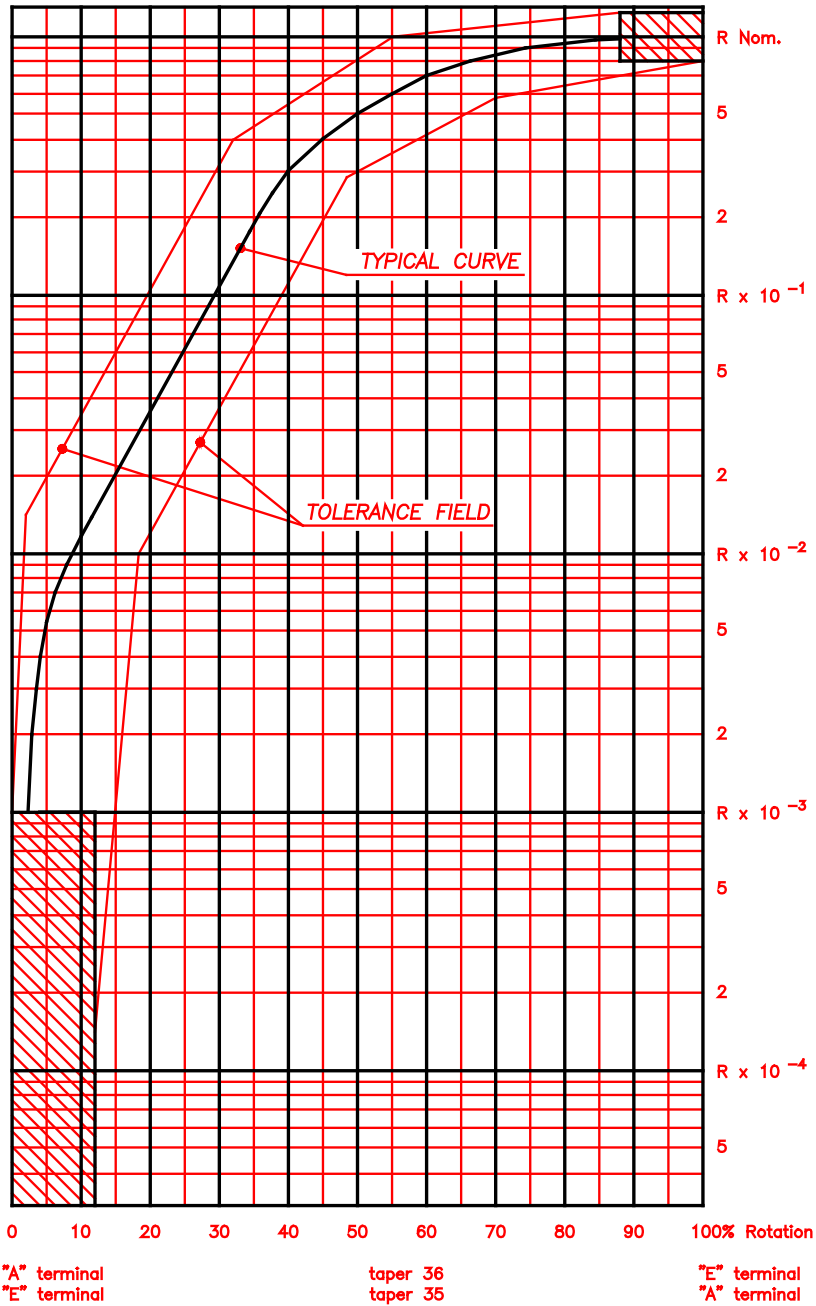

Taper Nos. 41-42

Negative logarithmic no. 41 - counter clockwise rotation

Positive logarithmic no. 42 - clockwise rotation

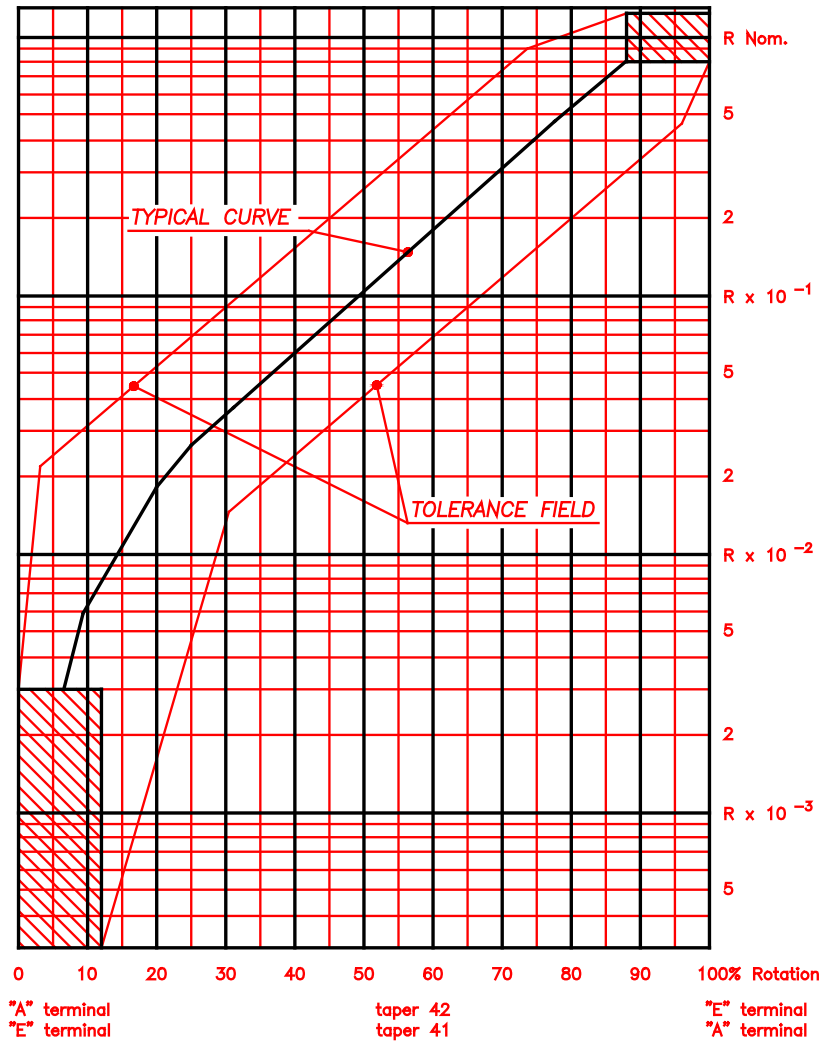

Taper Nos. 43-44

Negative double logarithmic no. 43 - counter clockwise rotation

Positive double logarithmic no. 44 - clockwise rotation

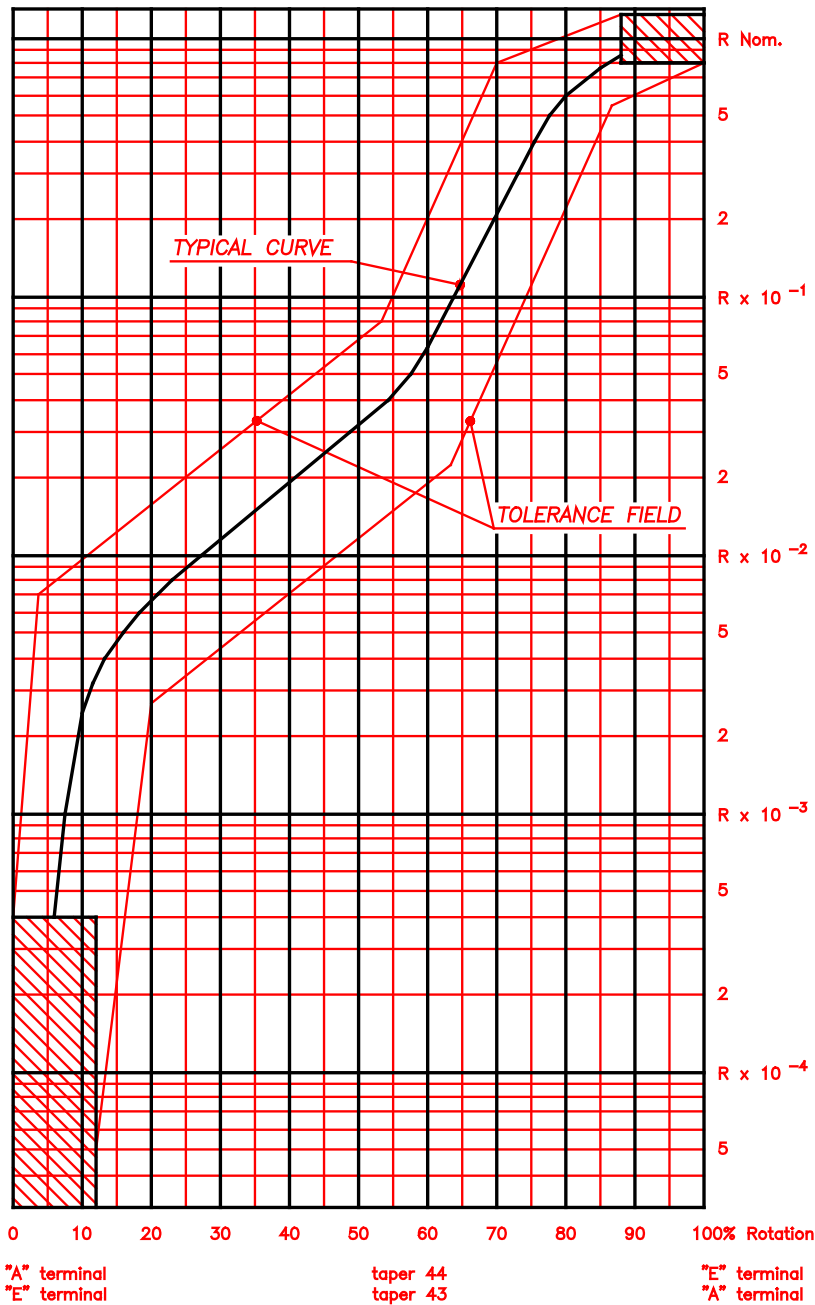

Taper Nos. 45-46

Negative double logarithmic no. 45 - counter clockwise rotation

Positive double logarithmic no. 46 - clockwise rotation

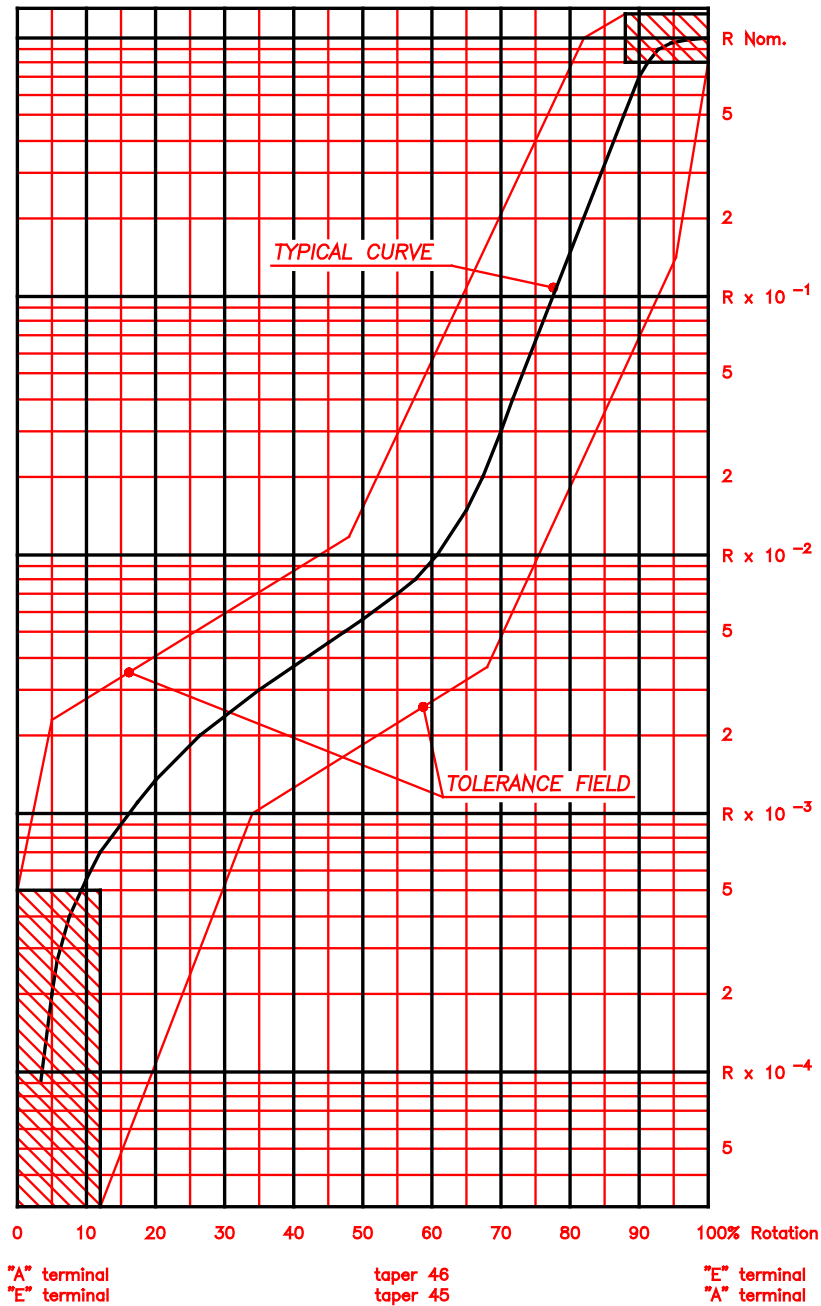

Taper Nos. 81-82

Negative double logarithmic no. 81 - counter clockwise rotation

Positive double logarithmic no. 82 - clockwise rotation

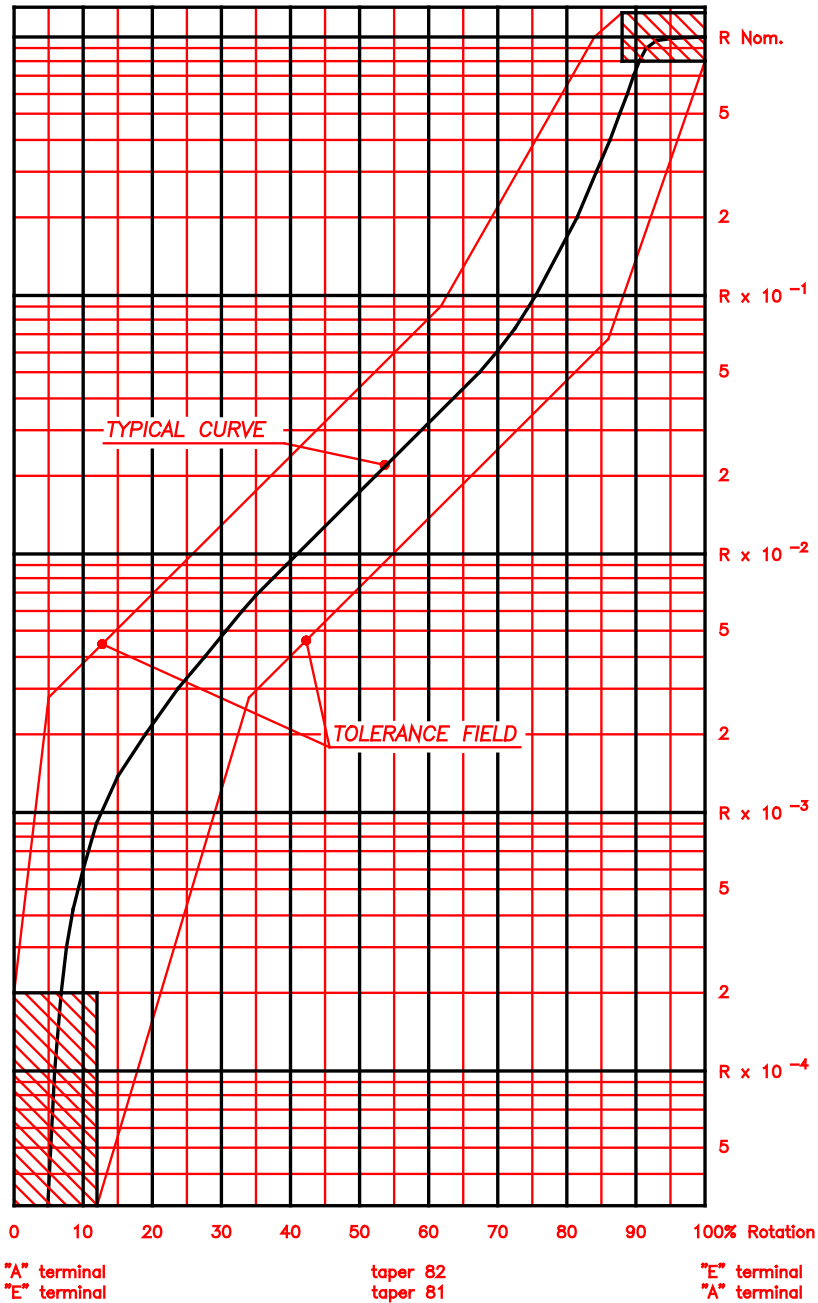

Taper Nos. 83-84

Negative double logarithmic no. 83 - counter clockwise rotation

Positive double logarithmic no. 84 - clockwise rotation

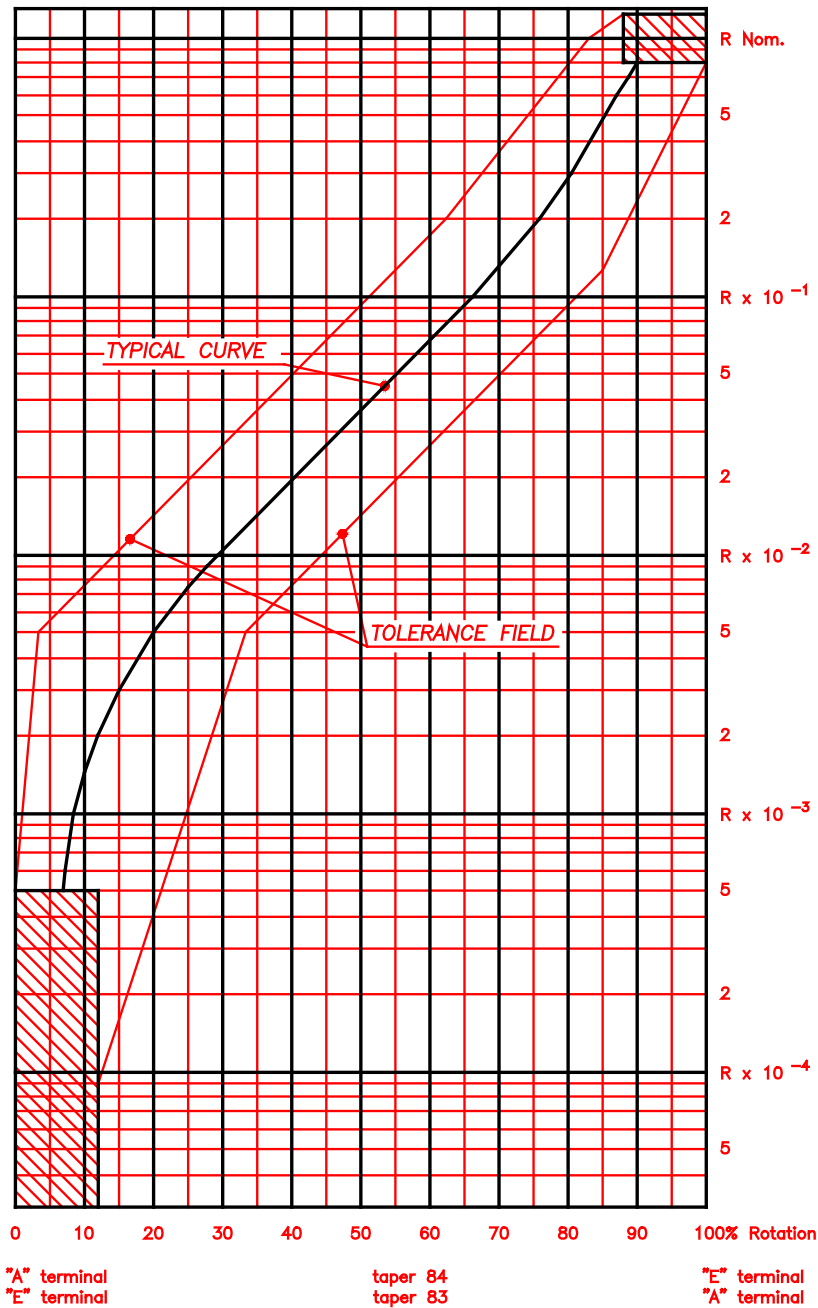

Taper Nos. 85-86

Negative double logarithmic no. 85 - counter clockwise rotation

Positive double logarithmic no. 86 - clockwise rotation

